

**Fixed SILpoint 2 Gas Alarm Devices of the SP1 series with Ex db protection for Zone 1 and 2. SP2 series with Ex nA protection only for Zone 2. Designed for the continuous monitoring of the ambient air to detect combustible gases and vapours for use in the hazardous areas of zones 1 and/or 2 according to Directive 2014/34/EU.**

Microprocessor based gas sensor with 4–20 mA / RS485 Modbus output signal, alarm and fault relays (all SIL2 certified) for monitoring the ambient air to detect combustible gases and vapours by means of a catalytic sensor element (Pellistor).

The calibration of sensors without LCD display is carried out via the calibration device STL06-PGX2 or the PC soft-ware PCE06-PGX2. Sensors with LCD display have an integrated calibration routine that is started from the outside by a permanent magnet without opening the housing. In case of an alarm or failure the backlight of sensors with LCD display changes from green to red.

## Key Features

- ATEX and IEC Ex certificates
- **SP1 for zone 1 (and also suitable for zone 2):**
  - Type "Ex db" with flame-proof enclosure
- **SP2 for zone 2:**
  - Type "Ex nA" with flame-proof enclosure
- Enclosure: additional FM and CSA certificates for Class I, Div. 1
- Continuous monitoring
- Microprocessor with 12-bit converter resolution
- Self-monitoring system
- Easy calibration
- Calibration service by exchanging the sensor head
- Proportional 4–20 mA output
- Serial interface to the control center
- Reverse polarity protection
- Overload protection
- LCD display with status LEDs (optional)
- Alarm and fault signal relay (optional)



**SENSOR WITH ALARM**



**SENSOR WITHOUT DISPLAY**

## Application

The SILpoint sensor is used in industrial areas like oil/gas industry, biogas plants, petrochemical industry, power plants etc. in Ex-Zone 1 (SP1) and/or 2 (SP2). The SILpoint sensor is also suitable for commercial areas like gas transfer stations etc. With the 4–20 mA / RS485-ModBus output signal the sensor is suitable for connection to the Combi series, as well as to any other controllers or automation devices. Optionally, the SILpoint sensor is also available with LCD display and relay output.

## GENERAL SPECIFICATIONS

### ELECTRICAL

<b>Power supply SP1 series</b>	20–28 V DC reverse polarity protected
<b>Power supply SP2 series</b>	20–28 V DC reverse polarity protected or 24 V AC $\pm$ 10 % (21.6–26.4 V AC)
<b>Power consumption (at 24 V DC)</b>	Max. 130 mA
<b>Control unit</b>	Microprocessor with 12-bit converter resolution
<b>Digital filter</b>	Averaging in order to increase the EMC immunity
<b>Visual indications</b>	3 LEDs for power, alarm and fault
<b>Analog output signal (active)</b>	Proportional, overload and short-circuit proof, load $\leq$ 500 $\Omega$ 4–20 mA = measuring range 3.0–4 mA = underrange > 20–21,2 mA = overrange 2 mA = fault > 21.8 mA = fault High
<b>Serial output (optional)</b>	Serial data bus
<b>Faulty relay output (optional)</b>	Max. 30 V AC/DC, 1 A
<b>Alarm relay (optional)</b>	Max. 30 V AC/DC, 1 A
<b>LCD (optional)</b>	2 x 16 characters, 3 status LEDs, 4 menu operating elements

### SENSOR DATA

<b>Gas type and measuring range</b>	Combustible gases, see Ordering Information
<b>Sensor element</b>	Pellistor (catalytic bead) sensor
<b>Stabilization time</b>	24 h
<b>Warm-up time</b>	300 s
<b>Temperature range</b>	-30 °C to +60 °C (-22 °F to 140 °F)
<b>Humidity range</b>	0–95 % RH not condensing
<b>Pressure range</b>	Atmospheric $\pm$ 10 %
<b>Storage temperature range</b>	0 °C to +20 °C (32 °F to 68 °F)
<b>Storage time <sup>1</sup></b>	6 months
<b>Sensor lifetime</b>	5 years / normal ambient conditions
<b>Poisoning</b>	Sensitivity of Pellistor sensors can be influenced by substances contain-ing silicon compounds and even poisoned and destroyed by them. The sensors are also susceptible to poisoning by organic solvents.

### SENSOR HEAD HOUSING

<b>Material</b>	CrNi Stahl: 1.4404
<b>Dimensions (d x H)</b>	30 x 56 mm (1.18 x 2.20 in.)
<b>Protection class</b>	Gas inlet IP64, with option splash proof IP66 SplashGuard (on request)
<b>Thread</b>	External thread NPT 3/4" ANSI/ B1.20.1

## PHYSICAL CHARACTERISTICS

Enclosure P1 and P3 / colour	Aluminium pressure die-casting / light grey RAL 7032, epoxy coating
Dimensions (d x H) / weight	95 x 82 mm / approx. 1.3 kg
Protection class	Housing protection IP66 to IP68 (depending on the cable glands used)
Mounting	Wall mounting (sensor head downwards)
Cable entry	1x resp. 3x ¾ in. (Ansi B1.20.1)
Wire connection	Spring-type terminal, 0.08 to 2.5 mm <sup>2</sup> AWG 28–12
Wire length	Max. load 500 Ω (= wire resistance + controller input resistance)

## ENVIRONMENTAL CONDITIONS (OPERATION AND EXPLOSION PROTECTION)

Humidity	20 to 90% RH (not condensing)
Operating temperature	-25 °C to +60 °C (-13 °F to 140 °F), -20 °C to +60 °C (-4 °F to 140 °F) for display version
Storage temperature	-5 °C to +30 °C (23 °F to 86 °F)
Pressure range <sup>2</sup>	800 to 1200 mbar (80 to 120 kPa)
Air velocity	< 6 m/sec.

1 We recommend recalibrating the devices if stocked for a longer period (> 8 weeks).

2 The explosion protection test only covers the pressure range up to 1100 mbar and the oxygen concentration up to 21 % vol.

## MARKING / CERTIFICATES

	SP1	SP2
ATEX Marking	II2G Ex db IIC T4 Gb, CE 0158	II3G Ex nA IIC T4 Gc
EC-Type Examination Certificate	BVS 15 ATEX E 129 X	
Protection types	EN 60079-0: 2012 and EN 60079-1: 2014 (Ex-db)	EN 60079-0: 2012 and EN 60079-15: 2011 (Ex-nA)
Measurement function	EN 60079-29-1 (pending)	
Certificates	IECEx BSV 16.0038 X (electrical Ex protection), IEC 60079-0, -1 (Ex db)	
Functional safety SIL2 (only Pellistors)	EN 50271: 2010; EN 50402: 2016 and EN 61508: 2011 (parts 1-3)	

## Certificates only housing

FM Certificate	<b>Class 3600, Class 3615, Class 3810, ANSI/NEMA 250.</b> Explosionproof for Class I, Division 1, Groups A, B, C and D; dust-ignition-proof for Class II, Division 1, Groups E, F and G, Class III, hazardous (classified) locations, indoors and outdoors (type 4X).
CSA Certificate	2472857 / Class 2258-02 PROCESS CONTROL EQUIPMENT for hazardous locations Class I, Div. 1, Groups A, B, C and D; Class II, Div. 1, Groups E, F and G, Class III, Div. 1; Type 4X

## WARRANTY

	1 year on sensor (not if poisoned or overloaded), 2 years on device
--	--



GAS TYPE	ORDERING NO.	MEASURING RANGE	ACCURACY	DISPLAY RESOLUTION	REPEATABILITY	T90 TIME	ZERO-POINT VARIATION	DRIFT IN AIR		CALIBRATION INTERVAL <sup>1</sup>
								ZERO	GAIN	
	PX2-SX1-	% LEL/ ppm	± % sig.	% LEL / ppm	<± %	≤ sec.	± % LEL	< % signal/ month		Months
CH <sub>4</sub>	P3400-A	0–100 % LEL	1 (CH <sub>4</sub> )	0.1	2 (CH <sub>4</sub> )	20	0.5 (CH <sub>4</sub> )	0.5 (CH <sub>4</sub> )	2 (CH <sub>4</sub> )	6
NH <sub>3</sub>	P3408-A	0–100 % LEL	1 (CH <sub>4</sub> )	0.1	2 (CH <sub>4</sub> )	25	0.5 (CH <sub>4</sub> )	0.5 (CH <sub>4</sub> )	2 (CH <sub>4</sub> )	6
NH <sub>3</sub>	P3408-B	0–20 % LEL	1 (CH <sub>4</sub> )	0.1	2 (CH <sub>4</sub> )	25	0.5 (CH <sub>4</sub> )	0.5 (CH <sub>4</sub> )	2 (CH <sub>4</sub> )	6
C <sub>3</sub> H <sub>8</sub>	P3480-A	0–100 % LEL	1 (CH <sub>4</sub> )	0.1	2 (CH <sub>4</sub> )	30	0.5 (CH <sub>4</sub> )	0.5 (CH <sub>4</sub> )	2 (CH <sub>4</sub> )	6
C <sub>3</sub> H <sub>8</sub>	P3480-B	0–30 % LEL	2 (C <sub>3</sub> H <sub>8</sub> )	0.01	2 (C <sub>3</sub> H <sub>8</sub> )	40	0.5 (C <sub>3</sub> H <sub>8</sub> )	n.d. (> 3% C <sub>4</sub> H <sub>10</sub> )	2 (CH <sub>4</sub> )	6
C <sub>3</sub> H <sub>8</sub>	3480-C	0–5000 ppm	2 (C <sub>3</sub> H <sub>8</sub> )	1 (ppm)	2 (C <sub>3</sub> H <sub>8</sub> )	40	0.5 (C <sub>3</sub> H <sub>8</sub> )	n.d. (> 3% C <sub>4</sub> H <sub>10</sub> )	2 (CH <sub>4</sub> )	6
All oth.	XXXX-A	0–100 % LEL	1 (CH <sub>4</sub> )	0.1	2 (CH <sub>4</sub> )	n.d.	0.5 (CH <sub>4</sub> )	0.5 (CH <sub>4</sub> )	2 (CH <sub>4</sub> )	6

<sup>1</sup> Manufacturer-recommended calibration interval for normal environmental conditions.

All specifications were collected under optimal test conditions.

We confirm compliance with the minimum requirements of the applicable standard.

## ELECTRICAL CONNECTION

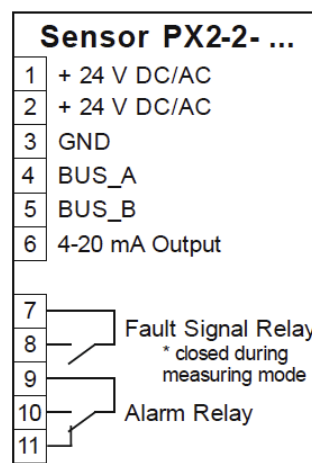
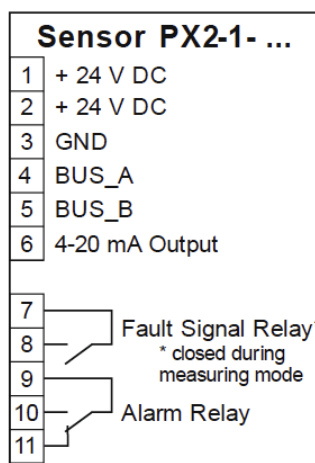

## ORDER INFORMATION

PX2-SX1-	X-1-	X-	PXXXX-X- PXXXX-X	XX	SENSOR			
				P1 P3	EXCHANGE HEAD <sup>1</sup>		Sensor housing	
				Gas type	Measuring range	Gas density (air = 1)		Mount. height
			<b>P3400-A*</b>	Methane, CH <sub>4</sub>	0-100 % LEL	0.56	Ceiling	
			<b>P3402-A**</b>	LPG	0-100 % LEL	n.d.		
			<b>P3408-A*2</b>	Ammonia, NH <sub>3</sub>	0-100 % LEL	0.60	Ceiling	
			<b>P3408-B*2</b>	Ammonia, NH <sub>3</sub>	0-20 % LEL	0.60	Ceiling	
			<b>P3410-A**</b>	Ethylene, C <sub>2</sub> H <sub>4</sub>	0-100 % LEL	0.97	1.5-1.8 m	
			<b>P3415-A**</b>	Cyclohexane, C <sub>6</sub> H <sub>12</sub>	0-100 % LEL	2.90	Floor	
			<b>P3420-A**</b>	Ethane, C <sub>2</sub> H <sub>6</sub>	0-100 % LEL	1.05	1.5-1.8 m	
			<b>P3425-A**</b>	Ethyl alcohol, C <sub>2</sub> H <sub>5</sub> OH	0-100 % LEL	1.59	Floor	
			<b>P3427-A**</b>	Ethyl acetate, C <sub>4</sub> H <sub>8</sub> O <sub>2</sub>	0-100 % LEL	3.04	Floor	
			<b>P3430-A**</b>	Benzene, C <sub>6</sub> H <sub>6</sub>	0-100 % LEL	2.70	Floor	
			<b>P3435-A*</b>	n-Hexane, C <sub>6</sub> H <sub>14</sub>	0-100 % LEL	2.97	Floor	
			<b>P3440-A*</b>	Hydrogen, H <sub>2</sub>	0-100 % LEL	0.07	Ceiling	
			<b>P3448-A**</b>	Butyl acetate, C <sub>6</sub> H <sub>12</sub> O <sub>2</sub>	0-100 % LEL	4.01	Floor	
			<b>P3450-A**</b>	Methanol, CH <sub>3</sub> OH	0-100 % LEL	1.10	Floor	
			<b>P3458-A**</b>	Methyl ethyl ketone, C <sub>4</sub> H <sub>8</sub> O	0-100 % LEL	2.48	Floor	
			<b>P3460-A**</b>	Iso/n-Butane, C <sub>4</sub> H <sub>10</sub>	0-100 % LEL	2.08	Floor	
			<b>P3468-A**</b>	Isobutyl alcohol, C <sub>4</sub> H <sub>10</sub> O	0-100 % LEL	2.55	Floor	
			<b>P3470-A**</b>	Octane, C <sub>8</sub> H <sub>18</sub>	0-100 % LEL	3.94	Floor	
			<b>P3472-A**</b>	Cyclopentane, C <sub>5</sub> H <sub>10</sub>	0-100 % LEL	2.42	Floor	
			<b>P3473-A**</b>	Methyl acetate, C <sub>3</sub> H <sub>6</sub> O <sub>2</sub>	0-100 % LEL	2.56	Floor	
			<b>P3475-A**</b>	Iso/n-Pentane, C <sub>5</sub> H <sub>12</sub>	0-100 % LEL	2.49	Floor	
			<b>P3480-A*</b>	Propane, C <sub>3</sub> H <sub>8</sub>	0-100 % LEL	1.55	Floor	
			<b>P3480-B**</b>	Propane, C <sub>3</sub> H <sub>8</sub>	0-30 % LEL	1.55	Floor	
			<b>P3480-C**</b>	Propane, C <sub>3</sub> H <sub>8</sub>	0-5000 ppm	1.55	Floor	
			<b>P3482-A*</b>	Isopropyl alcohol, C <sub>3</sub> H <sub>8</sub> O	0-100 % LEL	2.07	Floor	
			<b>P3485-A**</b>	Acetone, C <sub>3</sub> H <sub>6</sub> O	0-100 % LEL	2.00	Floor	
			<b>P3490-A**</b>	Toluene, C <sub>7</sub> H <sub>8</sub>	0-100 % LEL	3.18	Floor	
			<b>P3491-A**</b>	n-Heptane, C <sub>7</sub> H <sub>16</sub>	0-100 % LEL	3.46	Floor	
			<b>P3494-A**</b>	Butadiene, C <sub>4</sub> H <sub>6</sub>	0-100 % LEL	1.92	Floor	
			<b>P3495-A**</b>	Nonane, C <sub>9</sub> H <sub>20</sub>	0-100 % LEL	4.43	Floor	
			<b>P3496-A**</b>	Petrol Vapours	0-100 % LEL	n.d.	Floor	
		<b>0</b>	Without options					
		<b>1</b>	Relay set (2)					
		<b>2</b>	LC Display					
		<b>3</b>	Relay set (2) and LC Display					
	<b>1</b>	Zone 1 and 2						
	<b>2</b>	Zone 2						
							<b>Options</b> <b>ATEX Zone</b>	

\* Metrological testing according to EN 60079-29-1 by DEKRA Testing and Certification GmbH

\*\* Testing by the manufacturer (manufacturer's declaration of conformity)

1 The exchangeable sensor head is only to be used in connection with the SILpoint Gas Sensor. Otherwise it loses its ATEX Certification.

2 Only on request